

# SPECIFICATION

REFOND P/N

RF-A1A3F-R165-R1

R&D

Mass Production



## Contents

|   |     |
|---|-----|
| 1. Description  | 3   |
| 1.1 General Description   | 3   |
| 1.2 Features  | 3   |
| 1.3 Application   | 3   |
| 1.4 Package Dimension   | 4   |
| 1.6 Bin Range Of Forward Voltage and Luminous Intensity (IF=20mA) | BIN |
| (IF=20mA)   | 6   |
| 1.7 Typical Optical Characteristics Curves                        | 7   |
| 2. Packaging  | 11  |
| 2.1 Packaging Specification                                       | 11  |
| 2.1.1   |     |

REFOND

## 1. Description

### 1.1



The Red source color devices are made with AlGaInp on Substrate Light Emitting Diode .  
Product Package:3.50mmX2.80mmX1.84mm.

LED AlGaInp

3.50mmX2.80mmX1.84mm.

### 1.2 Features

PLCC2 Package. PLCC2

Extremely wide viewing angle.

Suitable for all SMT assembly and solder process.

SMT

Available on tape and reel.

Moisture sensitivity level: Level 2.

Level2

Compliance with RoHS and REACH.

RoHS REACH

Qualifications: The product qualification test plan is based on the guidelines of AEC-Q101  
Stress Test Qualification for Automotive Grade Discrete Semiconductors

AEC-Q101

### 1.3 Application

Automotive Interior Lighting.  
Switches.





## 1.5 Product Parameters

Table 1-1 Electrical / Optical Characteristics at Ts=25°C

| Item                | Symbol      | Test Condition | Value |      |      | Unit    |
|---------------------|-------------|----------------|-------|------|------|---------|
|                     |             |                | Min.  | Typ. | Max. |         |
| Forward Voltage     | $V_F$       | $I_F=20mA$     | 1.8   | 2.0  | 2.5  | V       |
| Reverse Current     | $I_R$       | $V_R=5V$       | ---   | ---  | 10   | $\mu A$ |
| Luminous Intensity  | $I_V$       | $I_F=20mA$     | 800   | 1000 | 1500 | mcd     |
| Dominant wavelength | $\lambda_d$ | $I_F=20mA$     | 615   | 617  | 620  | nm      |
| Viewing Angle       | 2 1/2       | $I_F=20mA$     | ---   | 120  | ---  | deg     |
| Thermal Resistance. | $R_{THJ-S}$ | $I_F=20mA$     | ---   | ---  | 260  | /W      |

Table 1-2 Absolute Maximum Ratings at Ts=25°C

| Parameter                     | Symbol    | Rating     | Units |
|-------------------------------|-----------|------------|-------|
| Power Dissipation             | $P_D$     | 75         | mW    |
| Forward Current               | $I_F$     | 30         | mA    |
| Peak Forward Current          | $I_{FP}$  | 100        | mA    |
| Reverse Voltage               | $V_R$     | 5          | V     |
| Electrostatic Discharge (HBM) | $E_{SD}$  | 8000       | V     |
| Operating Temperature         | $T_{OPR}$ | -40 ~ +100 |       |
| Storage Temperature           | $T_{STG}$ | -40 ~ +100 |       |
| Junction Temperature          | $T_J$     | 120        |       |

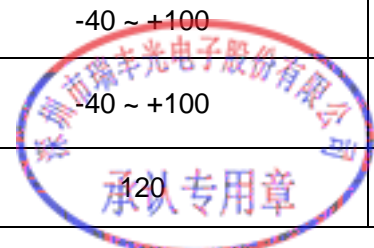

**Notes**

1. 1/10 Duty cycle, 10ms pulse width.      10ms,      1/10.
2. The above forward voltage measurement allowance tolerance is  $\pm 0.1V$ .       $\pm 0.1V$ .
3. The above color coordinates measurement allowance tolerance is  $\pm 0.005$ .       $\pm 0.005$ .
4. The above luminous intensity measurement allowance tolerance  $\pm 10\%$ .       $\pm 10\%$ .
5. Care is to be taken that power dissipation does not exceed the absolute maximum rating of the product.
6. All measurements were made under the standardized environment of Refond.
7. When the LEDs are in operation the maximum current should be decided after measuring the package temperature, junction temperature should not exceed the maximum rate. LED
8. ESD yield is over 90% at 8000V ESD (HBM). ESD protection during products handling is needed. 90% LED  
ESD8000V

## 1.6 Bin Range Of Forward Voltage and Luminous Intensity (IF=20mA)

### BIN (IF=20mA)

Table 1-3

|                |           |           |           |         |         |         |         |
|----------------|-----------|-----------|-----------|---------|---------|---------|---------|
| V <sub>F</sub> | B1        | B2        | C1        | C2      | D1      | D2      | E1      |
|                | 1.8-1.9   | 1.9-2.0   | 2.0-2.1   | 2.1-2.2 | 2.2-2.3 | 2.3-2.4 | 2.4-2.5 |
| IV mcd         | L1        | L2        | M1        |         |         |         |         |
|                | 800-1000  | 1000-1200 | 1200-1500 |         |         |         |         |
| WD(nm)         | D1        | D2        |           |         |         |         |         |
|                | 615-617.5 | 617.5-620 |           |         |         |         |         |



## 1.7 Typical Optical Characteristics Curves

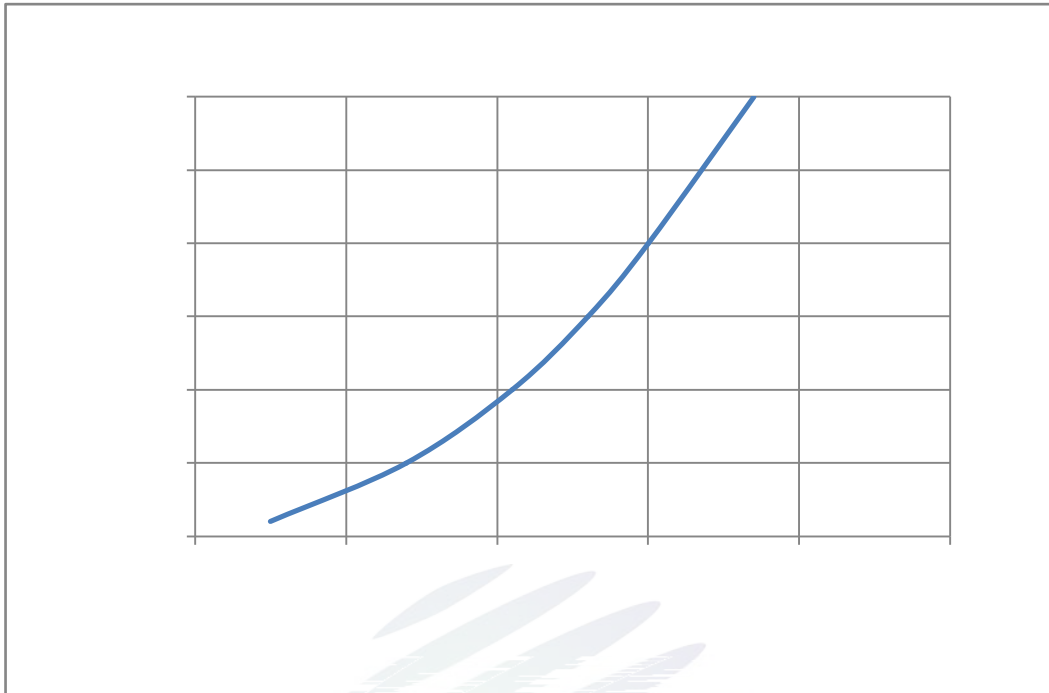

Fig. 1-7 Forward Voltage Vs Forward Current

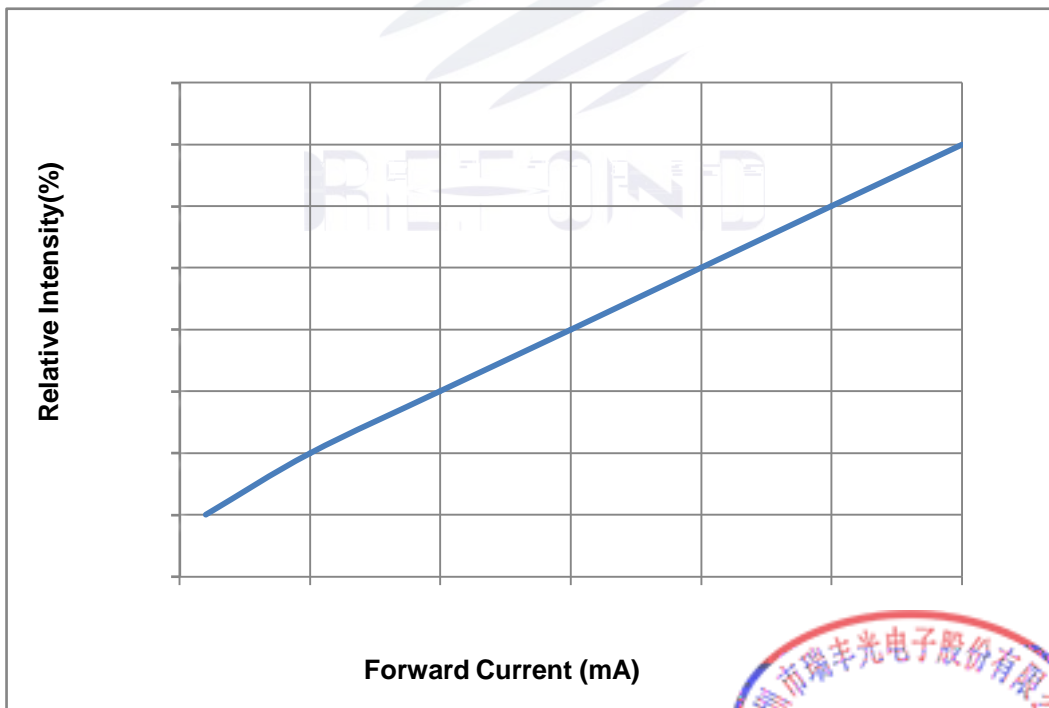
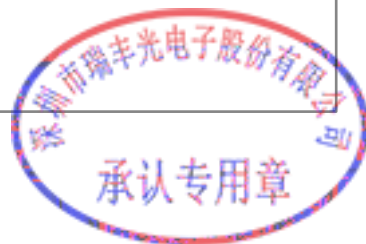

Fig. 1-8 Forward Current Vs Relative Intensity



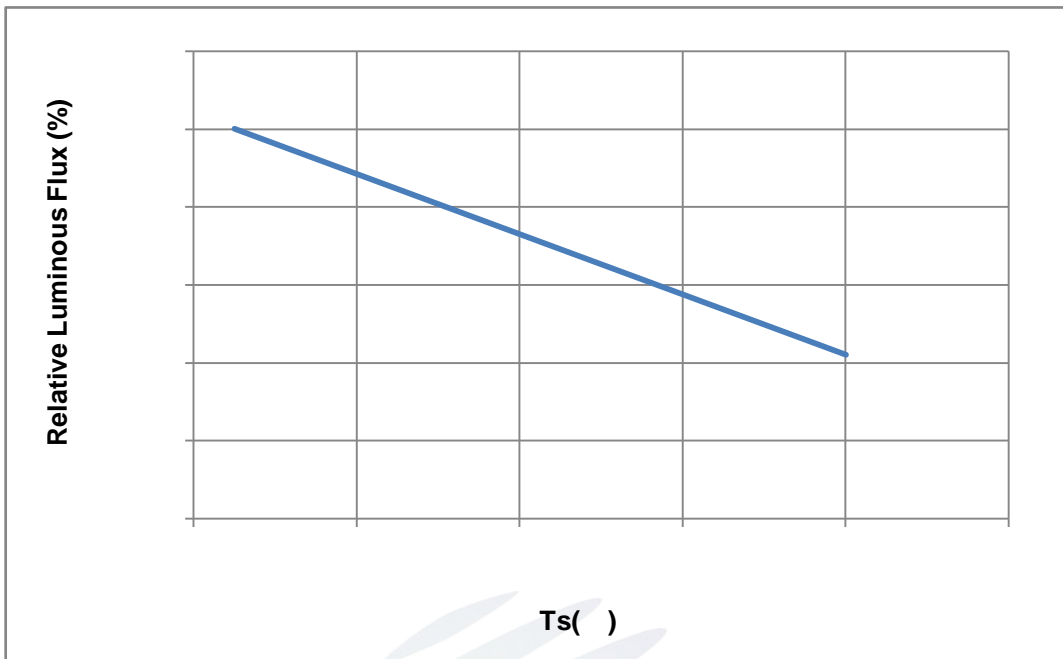

Fig. 1-9 Solder Temperature Vs Relative Intensity

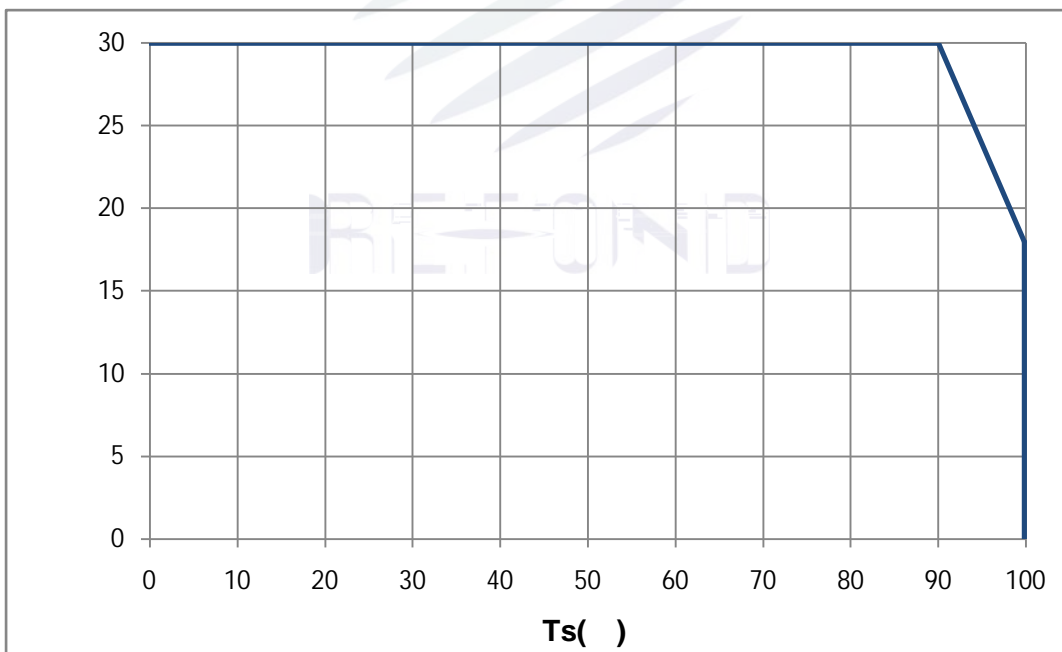

Fig. 1-10 Solder Temperature Vs Forward Current





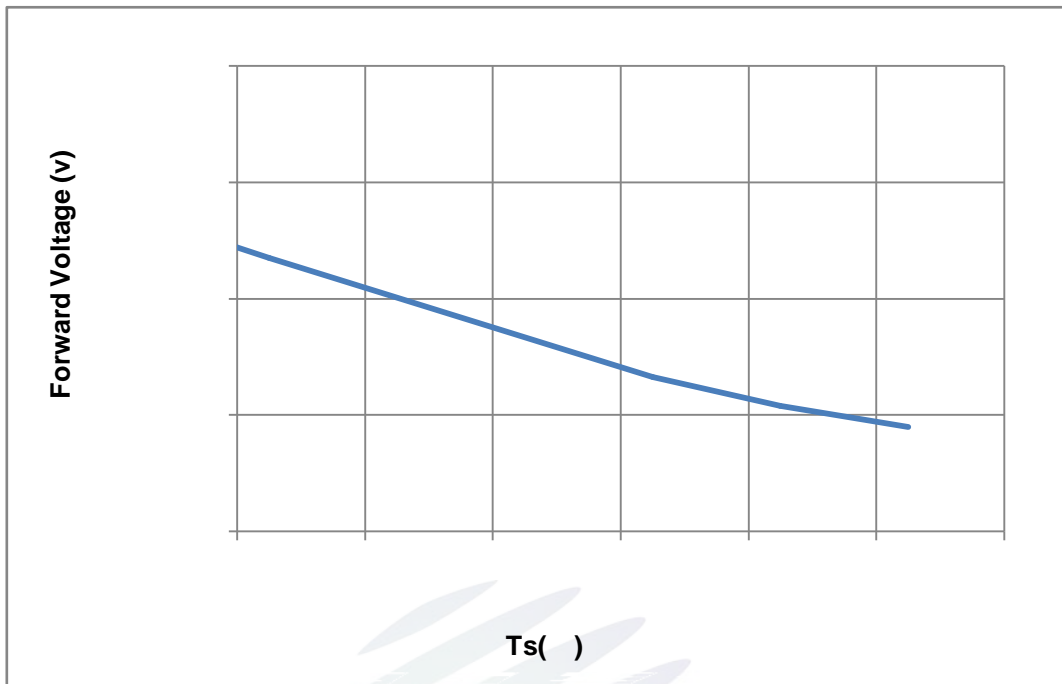

Fig. 1-11 Forward Voltage Vs Solder Temperature

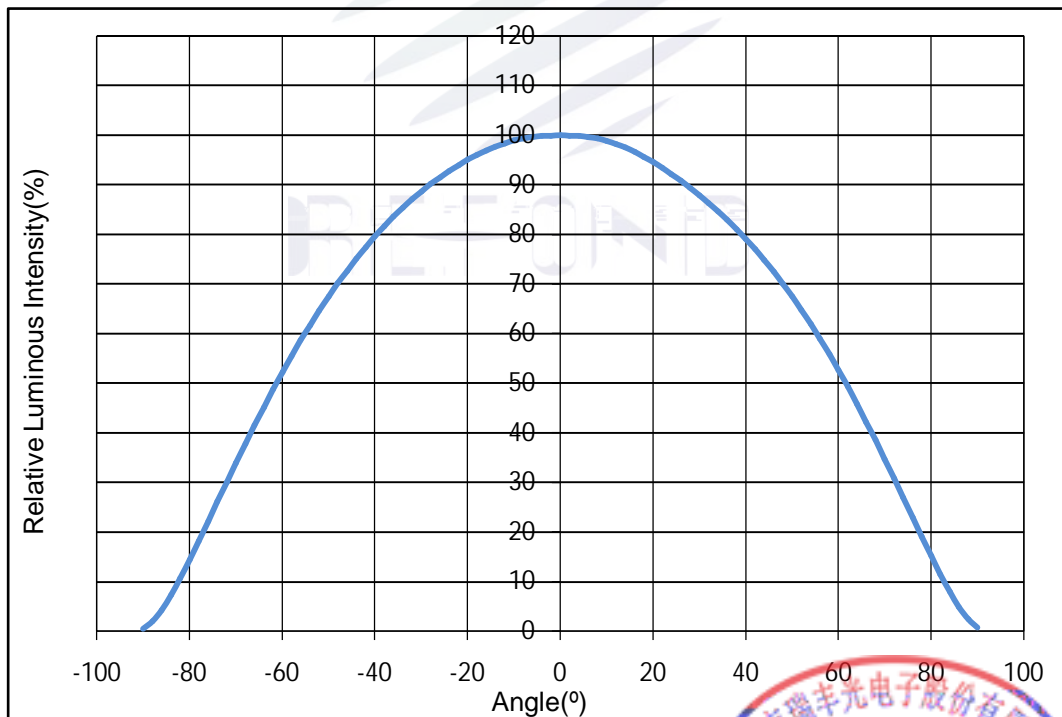
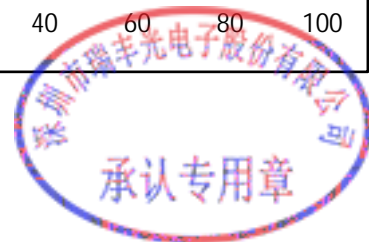

Fig. 1-12 Radiation diagram



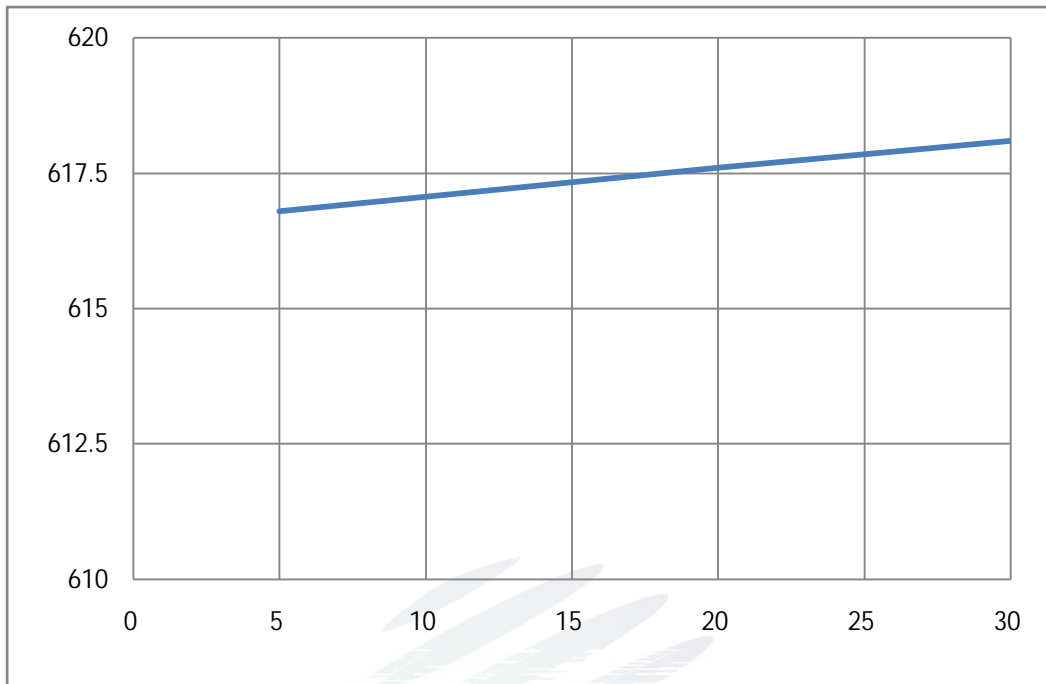

Fig. 1-13 Forward current vs. Dominate wavelength (Ts=25°C)

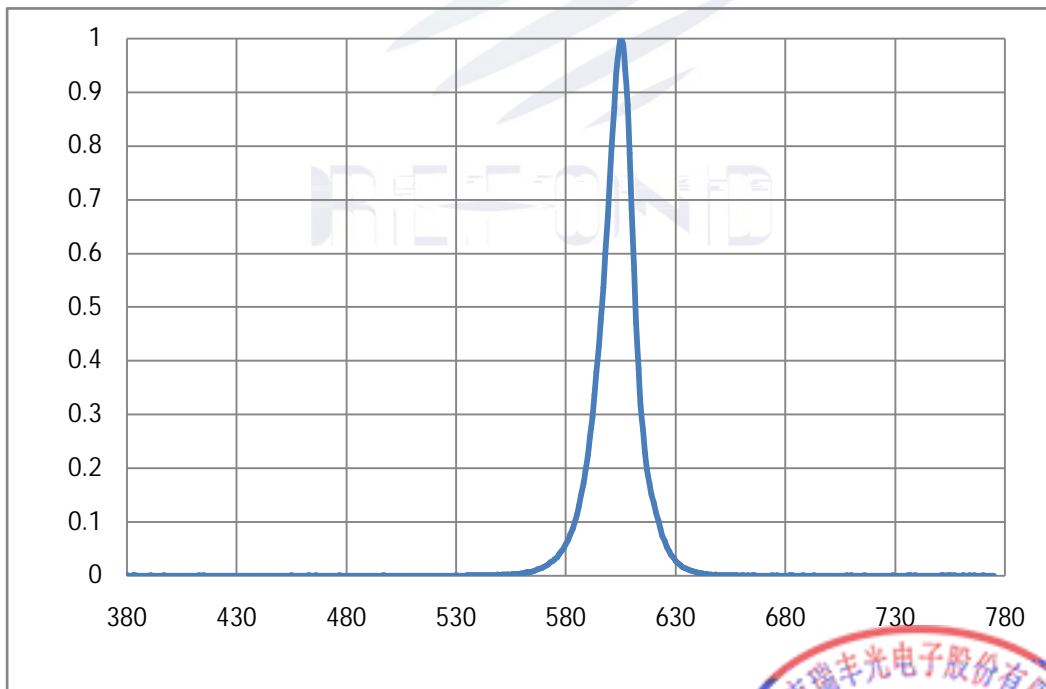
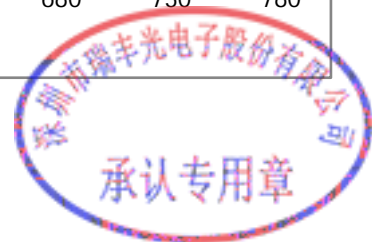

Fig. 1-14 Spectrum Distribution



## 2. Packaging

### 2.1 Packaging Specification

Package:2000pcs/reel.      2000pcs

#### 2.1.1 Carrier Tape Dimension mm

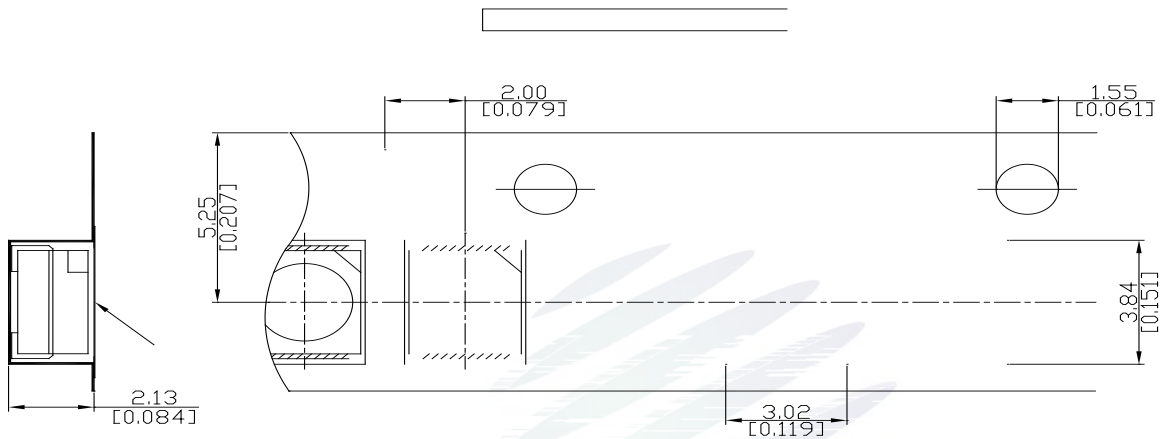

REFOND

### 2.1.3 Label Form Specification

Table 2-2 Specification

|                |                  |
|----------------|------------------|
| PART NO.       | Part Number      |
| SPEC NO.       | Spec Number      |
| LOT NO.        | Lot Number       |
| BIN CODE       | Bin Code         |
|                | Luminous flux    |
| XY             | Chromaticity Bin |
| V <sub>F</sub> | Forward Voltage  |
| WLD            | Wavelength       |
| QTY            | Packing Quantity |
| DATE           | Made Date        |

Fig. 2-3 Label Form Specification

### 2.2 Moisture Resistant Packing



Fig.2-4 Moisture Resistant Packing

### 2.3 Cardboard Box

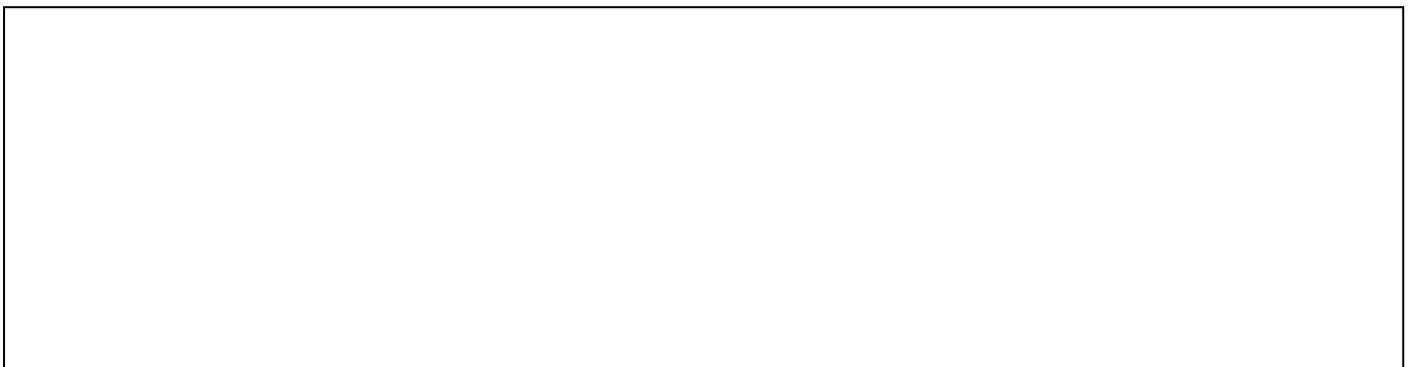

Fig.2- Cardboard Box

## 2.4 Reliability Test Items And Conditions

Table 2-3 Reliability Test Items And Conditions

| Test Items                                  | Ref.Standard           | Test Condition                | Time       | Quantity | Ac/Re<br>/ |
|---|------------------------|-------------------------------|------------|----------|------------|
| Reflow                                      | JESD22-B106            | Temp:260 max<br>T=10 sec      | 2times     | 20pcs.   | 0/1        |
| MSL2<br>2                                   | JESD22-A113            | 85 / 60%RH                    | 168 hrs.   | 20pcs.   | 0/1        |
| Thermal Shock                               | JEITAED-4701<br>300307 | -40 15min<br>10s<br>125 15min | 1000 cycle | 20pcs.   | 0/1        |
| Life Test                                   | JESD22-A108            | Ta=100<br>If=20mA             | 1000hrs.   | 20pcs.   | 0/1        |
| High Temperature<br>High Humidity Life Test | JESD22-A101            | 85 / 85%RH<br>If=20mA         | 1000hrs.   | 20pcs.   | 0/1        |



## 2.5 Criteria For Judging Damage

Table 2-4 Criteria For Judging Damage

| Test Items      | Symbol | Test Condition | Criteria For Judgement |             |
|-----------------|--------|----------------|------------------------|-------------|
|                 |        |                | Min.                   | Max.        |
| Forward Voltage | $V_F$  | $I_F=20mA$     | -                      | U.S.L*)x1.1 |
| Reverse Current | $I_R$  | $V_R = 5V$     | -                      | U.S.L*)x2.0 |
| Luminous Flux   |        | $I_F=20mA$     | L.S.L*)x0.7            | -           |

### Notes

- 1.U.S.L: Upper standard level                      L.S.L: Lower standard level
- 2.The above reliability tests is based on the verification of a single/strip LED of Refond's existing experimental platform,the reliability experiment was taken under good heat dissipation conditions. when customers applies the LED to the series and parallel circuit, should take consideration of all the factors such as the current, voltage distribution, heat dissipation and others. / LED  
LED
- 3.The technical information shown in the data sheets is limited to the typical characteristics and circuit examples of the referenced products. It does not constitute the warranting of industrial property nor the granting of any license.



### 3. SMT Reflow Soldering Instructions SMT

#### 3.1 SMT Reflow Soldering Instructions SMT

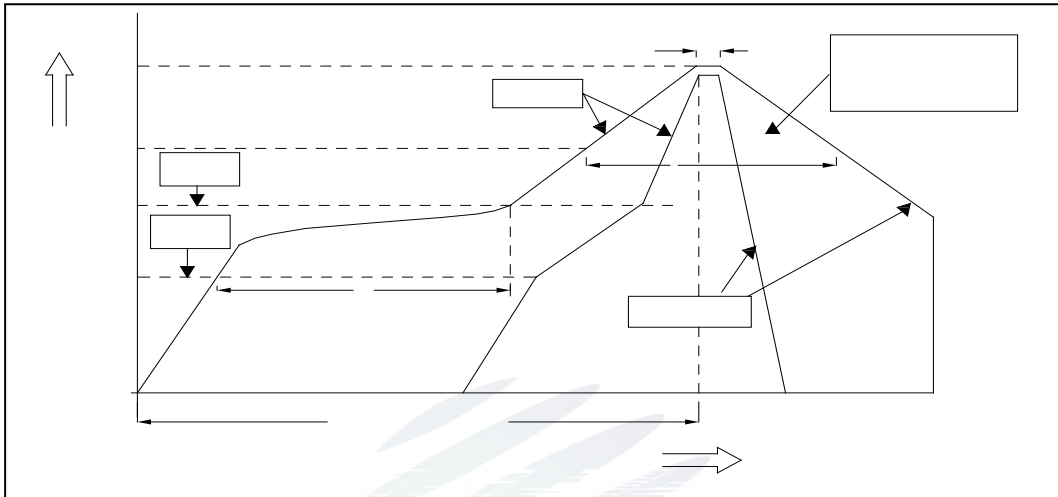
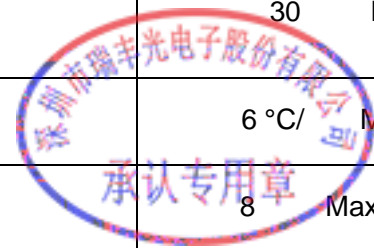

Fig.3-1 SMT Reflow Soldering Instructions SMT

Table 3-1 Reflow parameters

|  |                       |                   |
|--|-----------------------|-------------------|
| Average temperature rise speed   | $T_{smax}$ $T_P$      | 3 °C/ Max 3 °C/ s |
| Preheating: minimum temperature  | ( $T_{smin}$ )        | 150 °C            |
| Preheating: Max temperature  | ( $T_{smax}$ )        | 200 °C            |
| Preheating: Time   | $T_{smin}$ $T_{smax}$ | 60 - 120 60s-120s |
| Time limited to maintain high temperature: the temperature                 | ( $T_L$ )             | 217 °C            |
| Time limited to maintain high temperature: The Time                        | ( $t_L$ )             | 60 Max 60s        |
| Peak /Classification of temperature:                                       | / ( $T_P$ )           | 260 °C            |
| Time limit classification of peak temperature time                         | $t_p$                 | 10 Max 10s        |
| ( $T_P$ ) 5 °C Hold time within 5 °C with the actual peak temperature (TP) |                       | 30 Max 30s        |
| Cooling speed  |                       | 6 °C/ Max 6 °C/ s |
| 25 °C Needed time from 25 °C to $T_p$                                      |                       | 8 Max 8 minutes   |







## 4. Handling Precautions

### 4.1 Handling Precautions

(1) LED operating environment and sulfur element composition cannot be over 100PPM in the LED mating usage material. This is provided for informational purposes only and is not a warranty or endorsement. LED

LED

100PPM.

(2) In order to prevent external material from getting into the inside of LED, which may cause the malfunction of LED, the single content of Bromine element is required to be less than 900PPM, the single content of Chlorine element is required to be less than 900PPM, the total content of Bromine element and Chlorine element in the external materials of the application products is required to be less than 1500PPM. This is provided for informational purposes only and is not a warranty or endorsement.

LED

LED

REFOND

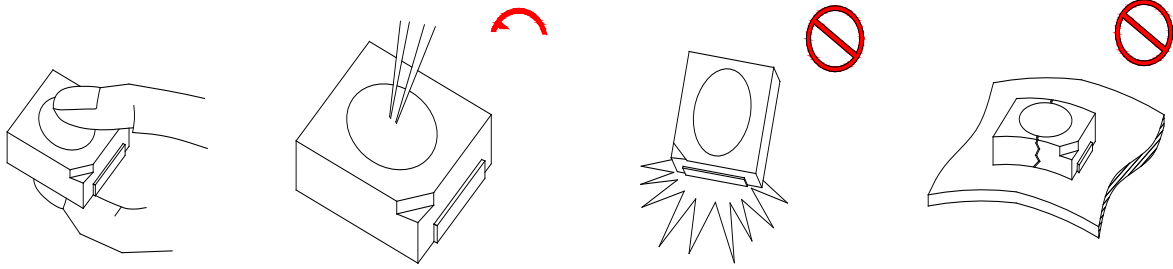

Fig 4-1 Handling Precautions

(5) In designing a circuit, the current through each LED can not exceed the absolute maximum rating specified for each LED. In the mean while, resistors for protection should be applied, other wise slight voltage shift will cause big current change, burn out may happen. The driving circuit must be designed to allow forward voltage only when it is ON or OFF. If the reverse voltage is applied to LED, migration can be generated resulting in LED damage.

LED

LED

(6) Thermal Design is paramount importance because heat generation may result in the Characteristics decline, such as brightness decreased, Color change and so on. Please consider the heat generation of the LEDs when making the system design.

LED

(7) Compared to standard encapsulants, silicone is generally softer, and the surface is more likely to attract dust, requiring special care during processing. In cases where a minimal level of dirt and dust particles cannot be guaranteed, a suitable cleaning solution must be applied to the surface after the soldering of components. Refond suggests using isopropyl alcohol for cleaning. In case other solvents are used, it must be assured that these solvents do not dissolve the package or resin. Ultrasonic cleaning is not recommended. Ultrasonic cleaning may cause damage to the LED.

LED

Table 4-1 Storage

| Conditions |                             | Temperature | Humidity | Time   |
|------------|-----------------------------|-------------|----------|--|
| Storage    | Before Opening Aluminum Bag | 30          | 75%      | Within 1 Year From Date                      |
|            | After Opening Aluminum Bag  | 30          | 60%      | Recommended for use<br>within 24 hours<br>24 |

Baking







REFOND



Declare

This specification is written both in English and in Chinese and the latter is formal.